

Townsend Bearings

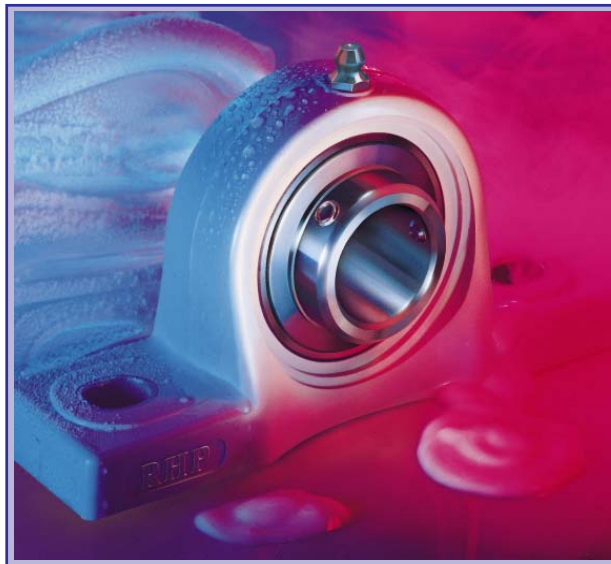

RHP Silver-lube Corrosion Resistant Bearing Units

STAINLESS STEEL

- Grease nipple
- Bolt hole liners
- Set screws
- Flinger
- Seal core
- Bearing rings, cage and balls



THERMOPLASTIC MOULDED HOUSING

- No coating
- No cracking
- No peeling
- Solid base

RHP SILVER-LUBE®

- CORROSION RESISTANT UNITS
- STAINLESS STEEL BEARING INSERTS
- EFFECTIVE, EFFICIENT SEALING
- APPROVED FOOD GRADE GREASE
- WIDE OPERATING TEMPERATURE
- END COVERS AVAILABLE

INTRODUCTION

The RHP Silver-Lube® series is a range of corrosion resistant bearing units specifically for use in industries where frequent thorough washdowns are necessary, optimum hygiene standards are required and good chemical resistance is important over a wide temperature range.

The units are available in pillow block, two-bolt flange, four-bolt flange and take-up unit configurations and are capable of accommodating initial misalignment from mounting errors. In operation the units have proven reliability in the most hostile applications.

Relubrication is possible for long trouble-free life, minimising maintenance, maximising productivity and helping maintain hygiene standards.

Silver-Lube® housings are made from PBT thermoplastic resin which, in addition to being non-corrodable, is resistant to detergents and a wide range of chemicals. The housings are paint and coating free which prevents chipping or flaking and have smooth surfaces to assist thorough washdowns.

Silver-Lube® bearing inserts are made from stainless steel, are provided with effective, efficient sealing arrangements and are charged with an aluminium complex, high temperature approved food grade grease, as standard.

Full technical specifications, application details and descriptions of the Silver-Lube® range are provided within this document.



FROM BOTTLING PLANTS TO FISHERIES

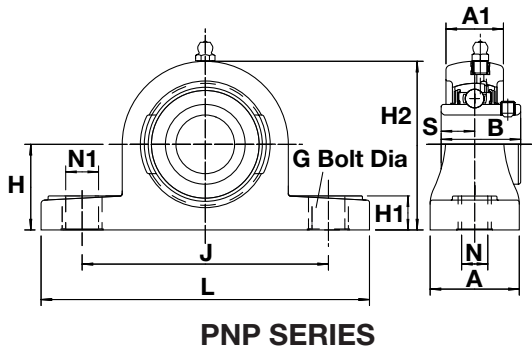

UNIT DIMENSIONS

Silver-Lube® mounting details are dimensionally interchangeable with the traditional RHP Self-Lube® range. However, some non-critical dimensions do differ, see tables below.

For permissible bearing speeds, please see page 14.

Table 1

PNP Silver-Lube® Pillow Blocks – Unit Dimensions

RHP DESIGNATION	SHAFT DIA.	BASIC INSERT	HOUSING GROUP	L	H	H1	H2	J	N	N1	G	A	A1	B	S	WEIGHT (kg)
PNP20CR	20	J1020	2	127.2	33.3	14.2	65.9	94.9	11.0	14.2	M10	37.8	22.5	31.0	12.7	0.27
PNP3/4CR	3/4"	J1020	2	127.2	33.3	14.2	65.9	94.9	11.0	14.2	M10	37.8	22.5	31.0	12.7	0.27
PNP25CR	25	J1025	3	140.2	36.5	14.5	71.9	104.9	11.0	14.2	M10	37.8	24.5	34.0	14.3	0.39
PNP1CR	1"	J1025	3	140.2	36.5	14.5	71.9	104.9	11.0	14.2	M10	37.8	24.5	34.0	14.3	0.39
PNP30CR	30	J1030	4	162.2	42.9	17.8	83.9	118.9	14.0	18.2	M12	45.8	27.0	38.1	15.9	0.52
PNP1.3/16CR	1.3/16"	J1030	4	162.2	42.9	17.8	83.9	118.9	14.0	18.2	M12	45.8	27.0	38.1	15.9	0.52
PNP1.1/4RCR	1.1/4"	J1030	4	162.2	42.9	17.8	83.9	118.9	14.0	18.2	M12	45.8	27.0	38.1	15.9	0.52
PNP35CR	35	J1035	5	167.2	47.6	18.0	94.9	126.9	14.0	18.2	M12	47.8	32.5	42.9	17.5	0.72
PNP1.1/4CR	1.1/4"	J1035	5	167.2	47.6	18.0	94.9	126.9	14.0	18.2	M12	47.8	32.5	42.9	17.5	0.72
PNP1.7/16CR	1.7/16"	J1035	5	167.2	47.6	18.0	94.9	126.9	14.0	18.2	M12	47.8	32.5	42.9	17.5	0.72
PNP40CR	40	J1040	6	184.2	49.2	19.5	98.9	136.8	14.0	18.2	M12	53.8	36.0	49.2	19.0	0.99
PNP1.1/2CR	1.1/2"	J1040	6	184.2	49.2	19.5	98.9	136.8	14.0	18.2	M12	53.8	36.0	49.2	19.0	0.99

All dimensions in mm except inch shaft sizes.

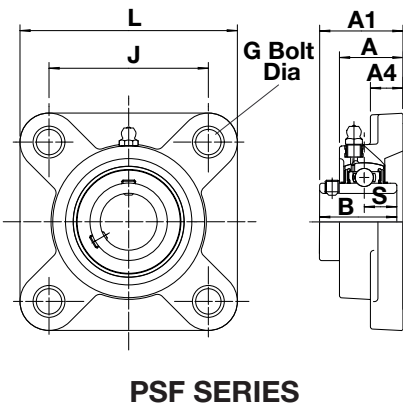

Table 2 PSF Silver-Lube® Four-Bolt Flange – Unit Dimensions

RHP DESIGNATION	SHAFT DIA.	BASIC INSERT	HOUSING GROUP	L	J	G	A	A1	A4	B	S	WEIGHT (kg)
PSF20CR	20	J1020	2	86.5	63.5	M10	27.8	36.3	13.4	31.0	12.7	0.28
PSF3/4CR	3/4"	J1020	2	86.5	63.5	M10	27.8	36.3	13.4	31.0	12.7	0.28
PSF25CR	25	J1025	3	95.0	70.0	M10	27.9	36.7	14.3	34.0	14.3	0.34
PSF1CR	1"	J1025	3	95.0	70.0	M10	27.9	36.7	14.3	34.0	14.3	0.34
PSF30CR	30	J1030	4	107.5	83.0	M10	31.5	41.4	14.3	38.1	15.9	0.50
PSF1.3/16CR	1.3/16"	J1030	4	107.5	83.0	M10	31.5	41.4	14.3	38.1	15.9	0.50
PSF1.1/4RCR	1.1/4"	J1030	4	107.5	83.0	M10	31.5	41.4	14.3	38.1	15.9	0.50
PSF35CR	35	J1035	5	117.5	92.0	M12	34.8	46.9	15.5	42.9	17.5	0.74
PSF1.1/4CR	1.1/4"	J1035	5	117.5	92.0	M12	34.8	46.9	15.5	42.9	17.5	0.74
PSF1.7/16CR	1.7/16"	J1035	5	117.5	92.0	M12	34.8	46.9	15.5	42.9	17.5	0.74
PSF40CR	40	J1040	6	130.5	102.0	M12	37.5	53.2	17.1	49.2	19.0	0.98
PSF1.1/2CR	1.1/2"	J1040	6	130.5	102.0	M12	37.5	53.2	17.1	49.2	19.0	0.98

All dimensions in mm except inch shaft sizes.

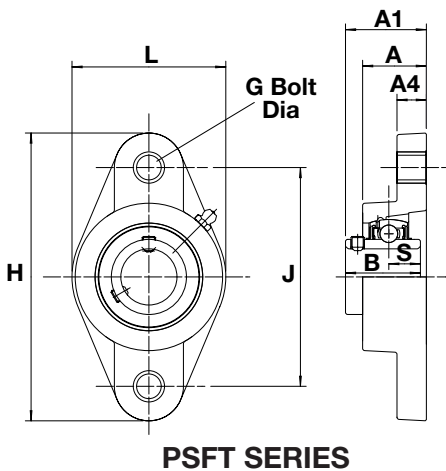
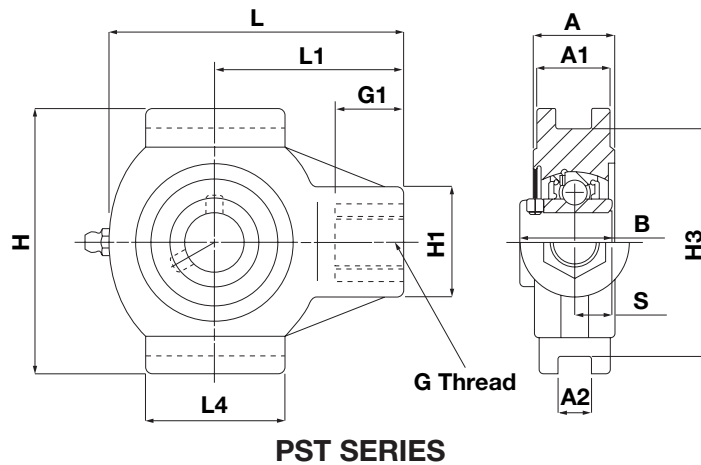

Table 3 PSFT Silver-Lube® Two-Bolt Flange – Unit Dimensions

RHP DESIGNATION	SHAFT DIA.	BASIC INSERT	HOUSING GROUP	L	H	J	G	A	A1	A4	B	S	WEIGHT (kg)
PSFT20CR	20	J1020	2	64.1	113.3	90.0	M10	26.5	33.7	11.4	31.0	12.7	0.24
PSFT3/4CR	3/4"	J1020	2	64.1	113.3	90.0	M10	26.5	33.7	11.4	31.0	12.7	0.24
PSFT25CR	25	J1025	3	68.4	130.3	99.0	M10	29.1	36.7	13.4	34.0	14.3	0.30
PSFT1CR	1"	J1025	3	68.4	130.3	99.0	M10	29.1	36.7	13.4	34.0	14.3	0.30
PSFT30CR	30	J1030	4	80.1	148.3	117.0	M10	30.5	41.2	13.4	38.1	15.9	0.44
PSFT1.3/16CR	1.3/16"	J1030	4	80.1	148.3	117.0	M10	30.5	41.2	13.4	38.1	15.9	0.44
PSFT1.1/4RCR	1.1/4"	J1030	4	80.1	148.3	117.0	M10	30.5	41.2	13.4	38.1	15.9	0.44
PSFT35CR	35	J1035	5	90.1	163.3	130.0	M12	32.8	43.4	16.1	42.9	17.5	0.64
PSFT1.1/4CR	1.1/4"	J1035	5	90.1	163.3	130.0	M12	32.8	43.4	16.1	42.9	17.5	0.64
PSFT1.7/16CR	1.7/16"	J1035	5	90.1	163.3	130.0	M12	32.8	43.4	16.1	42.9	17.5	0.64
PSFT40CR	40	J1040	6	100.1	175.3	144.0	M12	37.5	51.7	20.0	49.2	19.0	0.89
PSFT1.1/2CR	1.1/2"	J1040	6	100.1	175.3	144.0	M12	37.5	51.7	20.0	49.2	19.0	0.89

All dimensions in mm except inch shaft sizes.



PST SERIES

Table 4

PST Silver-Lube® Take-Up Units – Unit Dimensions

RHP DESIGNATION	SHAFT DIA.	BASIC INSERT	HOUSING GROUP	L	L1	L4	H	H1	H3	G	G1	A	A1	A2	B	S	WEIGHT (kg)
PST20CR	20	J1020	2	99.0	64.0	47.0	88.0	35.0	75.8	M16x2.00	22.5	27.5	24.5	12.2	31.0	12.7	0.32
PST3/4CR	3/4"	J1020	2	99.0	64.0	47.0	88.0	35.0	75.8	M16x2.00	22.5	27.5	24.5	12.2	31.0	12.7	0.32
PST25CR	25	J1025	3	99.0	64.0	47.0	88.0	35.0	75.8	M16x2.00	22.5	27.5	24.5	12.2	34.0	14.3	0.36
PST1CR	1"	J1025	3	99.0	64.0	47.0	88.0	35.0	75.8	M16x2.00	22.5	27.5	24.5	12.2	34.0	14.3	0.36
PST30CR	30	J1030	4	125.0	76.0	63.0	102.0	40.0	88.8	M16x2.00	22.5	34.5	30.0	12.2	38.1	15.9	0.53
PST1.3/16CR	1.3/16"	J1030	4	125.0	76.0	63.0	102.0	40.0	88.8	M16x2.00	22.5	34.5	30.0	12.2	38.1	15.9	0.53
PST1.1/4RCR	1.1/4"	J1030	4	125.0	76.0	63.0	102.0	40.0	88.8	M16x2.00	22.5	34.5	30.0	12.2	38.1	15.9	0.53
PST35CR	35	J1035	5	125.0	76.0	63.0	102.0	40.0	88.8	M16x2.00	22.5	34.5	30.0	12.2	42.9	17.5	0.74
PST1.1/4CR	1.1/4"	J1035	5	125.0	76.0	63.0	102.0	40.0	88.8	M16x2.00	22.5	34.5	30.0	12.2	42.9	17.5	0.74
PST1.7/16CR	1.7/16"	J1035	5	125.0	76.0	63.0	102.0	40.0	88.8	M16x2.00	22.5	34.5	30.0	12.2	42.9	17.5	0.74
PST40CR	40	J1040	6	140.0	85.0	80.0	114.0	40.0	101.8	M16x2.00	22.5	34.0	32.0	16.2	49.2	19.0	1.00
PST1.1/2CR	1.1/2"	J1040	6	140.0	85.0	80.0	114.0	40.0	101.8	M16x2.00	22.5	34.0	32.0	16.2	49.2	19.0	1.00

All dimensions in mm except inch shaft sizes.

END COVERS

Polypropylene end covers are available to fit all Silver-Lube® housings. End covers can be used at temperatures ranging from -20°C to $+90^{\circ}\text{C}$. They may be used as additional protection for the bearing in adverse environmental conditions as well as an aid to meeting safety requirements.

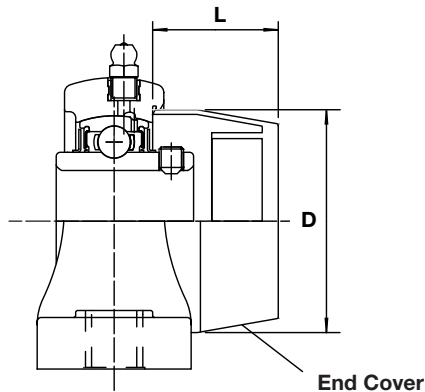

END COVER DETAIL

Table 5 End Cover Dimensions

HOUSING GROUP	END COVER REFERENCE	DIMENSION D	DIMENSION L
Group 2	P20P	50	23
Group 3	P25P	55	25
Group 4	P30P	64	30
Group 5	P35P	74	32
Group 6	P40P	84	37

All dimensions in mm.



SILVER-LUBE® HOUSINGS

Silver-Lube® housings are manufactured from highgrade PBT, a high quality thermoplastic which has excellent strength, rigidity, dimensional stability and chemical resistance.

PROPERTIES OF PBT

PROPERTY	UNITS	TEST METHOD	VALUES
----------	-------	-------------	--------

PHYSICAL

Density	g/cm ³	DIN 53479	1.53
Water Absorption(23°C)	%	DIN 53495	0.5
Mould Shrinkage	%	–	0.4
Moisture Absorption (23°)	%	DIN 53714	0.2

MECHANICAL

Tensile Yield Strength	MPa	ASTM D638	130
Elongation At Break	%	ASTM D638	3.5
Flexural Strength	MPa	ASTM D790	180
Flexural Modulus	MPa	ASTM D790	7,000
Notched IZOD Impact	J/m	ASTM D256	120

THERMAL

HDT At Load 1.8 Mpa	°C	DIN 53461	210
HDT AT Load 0.45 Mpa	°C	DIN 53461	220
Melting Point	°C	–	225
UL Flammability (*Thickness)	–	UL 94	HB
Max. Temp' In Glow Wire Test	°C	IEC 695/2/1	
2 mm thickness			750
4 mm thickness			960

ELECTRICAL

Dielectric Constant At 1 MHz	–	IEC 250	3.8
Dielectric Strength	kV/mm	VDE 0303/2	34
Volume Resistivity	ohm x cm	VDE 0303/2	>10 ¹⁵
Surface Resistivity	ohm	VDE 0303/3	>10 ¹⁵

PLASTIC HOUSING DIMENSIONAL ACCURACY

Table 6 PNP Silver-Lube® Pillow Blocks – Dimensional Accuracy

HOUSING GROUP	DEVIATIONS H	DEVIATIONS J
2	±150	±700
3	±150	±700
4	±150	±700
5	±150	±700
6	±150	±700

All dimensions in μm .

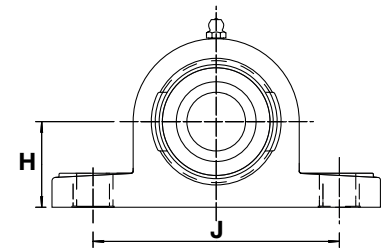

PNP SERIES

Table 7 PSF Silver-Lube® Four-Bolt Flange – Dimensional Accuracy

HOUSING GROUP	CENTRE HEIGHT A	HOLE CENTRES J	FIXING HOLE LOCATION X
2	±500	±700	200
3	±500	±700	200
4	±500	±700	200
5	±500	±700	200
6	±500	±700	200

All dimensions in μm .

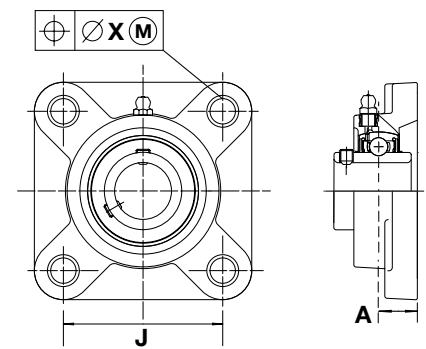

PSF SERIES

Table 8 PSFT Silver-Lube® Two-Bolt Flange – Dimensional Accuracy

HOUSING GROUP	CENTRE HEIGHT A	HOLE CENTRES J	FIXING HOLE LOCATION X
2	±500	±700	200
3	±500	±700	200
4	±500	±700	200
5	±500	±700	200
6	±500	±700	200

All dimensions in μm .

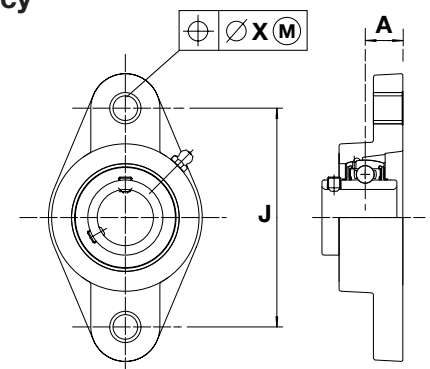

PSFT SERIES

Table 9 PST Silver-Lube® Take-Up Housings – Dimensional Accuracy

HOUSING GROUP	DEVIATIONS A	DEVIATIONS H
2	+200/0	0/-500
3	+200/0	0/-500
4	+200/0	0/-500
5	+200/0	0/-500
6	+200/0	0/-500

All dimensions in μm .

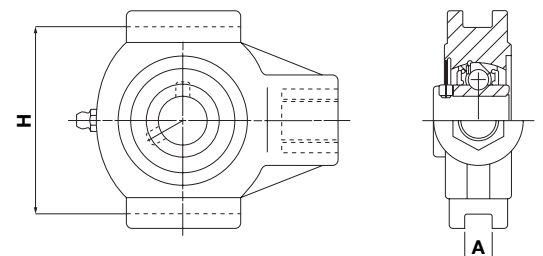

PST SERIES



HOUSING STRENGTH

Housing load carrying capacity varies depending on the application loading regime, which may be intermittent, continuous or cyclical. Maximum housing loads are given in tables 10, 11, 12 and 13. These loads must not be exceeded without prior consultation with NSK.

Published housing maximum load capacities do not allow for any reduction in housing strength caused by exposure of the housing to chemicals, water, steam, heat, ultraviolet light or any combination of these factors. If any of these factors are present in the application the designer or end-user must establish the effect of these exposures and reduce the published maximum housing load accordingly.

To maximise load carrying capacity it is recommended that washers are used with the fixing bolts. Tables 10, 11 and 12 also detail maximum fixing bolt tightening torques.

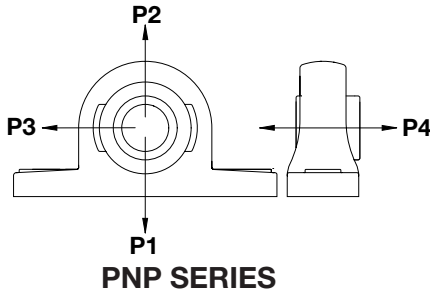

Table 10

PNP Silver-Lube® Pillow Blocks – Housing Load Capacity

RHP DESIGNATION	MAXIMUM HOUSING LOAD (N) AT 20°C												MAXIMUM FIXING BOLT TORQUE (Nm)
	P1			P2			P3			P4			
	INTERMITTENT LOADING	CONTINUOUS LOADING	CYCLICAL LOADING	INTERMITTENT LOADING	CONTINUOUS LOADING	CYCLICAL LOADING	INTERMITTENT LOADING	CONTINUOUS LOADING	CYCLICAL LOADING	INTERMITTENT LOADING	CONTINUOUS LOADING	CYCLICAL LOADING	
PNP20CR	3500	1700	800	2800	1400	800	2600	1300	700	1300	700	400	18
PNP3/4CR	3500	1700	800	2800	1400	800	2600	1300	700	1300	700	400	18
PNP25CR	4000	2000	1000	3100	1500	800	2600	1300	700	1700	900	500	25
PNP1CR	4000	2000	1000	3100	1500	800	2600	1300	700	1700	900	500	25
PNP30CR	5000	2500	1200	3500	1800	1000	4000	2000	1100	2600	1300	700	30
PNP1.3/16CR	5000	2500	1200	3500	1800	1000	4000	2000	1100	2600	1300	700	30
PNP1.1/4RCR	5000	2500	1200	3500	1800	1000	4000	2000	1100	2600	1300	700	30
PNP35CR	6000	3000	1500	4300	2100	1200	4100	2100	1100	3200	1600	900	35
PNP1.1/4CR	6000	3000	1500	4300	2100	1200	4100	2100	1100	3200	1600	900	35
PNP1.7/16CR	6000	3000	1500	4300	2100	1200	4100	2100	1100	3200	1600	900	35
PNP40CR	10700	5300	2900	8000	4000	2200	6800	3400	1900	5200	2600	1400	40
PNP1.1/2CR	10700	5300	2900	8000	4000	2200	6800	3400	1900	5200	2600	1400	40

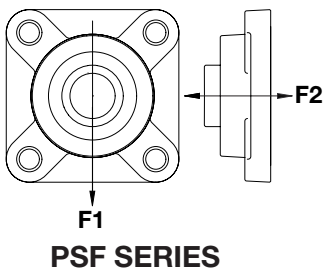
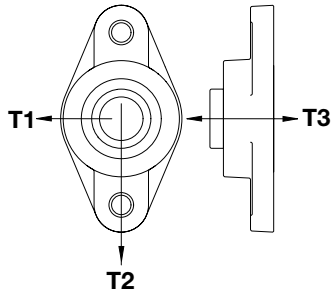

Table 11 PSF Four-Bolt Flange – Housing Load Capacity

RHP DESIGNATION	MAXIMUM HOUSING LOAD (N) AT 20°C						MAXIMUM FIXING BOLT TORQUE (Nm)
	F1			F2			
	INTERMITTENT LOADING	CONTINUOUS LOADING	CYCLICAL LOADING	INTERMITTENT LOADING	CONTINUOUS LOADING	CYCLICAL LOADING	
PSF20CR	3100	1600	900	1300	700	400	18
PSF3/4CR	3100	1600	900	1300	700	400	18
PSF25CR	3500	1700	1000	1300	700	400	25
PSF1CR	3500	1700	1000	1300	700	400	25
PSF30CR	4600	2300	1300	2200	1100	600	30
PSF1.3/16CR	4600	2300	1300	2200	1100	600	30
PSF1.1/4RCR	4600	2300	1300	2200	1100	600	30
PSF35CR	6200	3100	1700	2600	1300	700	35
PSF1.1/4CR	6200	3100	1700	2600	1300	700	35
PSF1.7/16CR	6200	3100	1700	2600	1300	700	35
PSF40CR	6200	3100	1700	4000	2000	1100	40
PSF1.1/2CR	6200	3100	1700	4000	2000	1100	40



PSFT SERIES

Table 12 PSFT Silver-Lube® Two-Bolt Flange – Housing Load Capacity

RHP DESIGNATION	MAXIMUM HOUSING LOAD (N) AT 20°C									MAXIMUM FIXING BOLT TORQUE (Nm)
	T1			T2			T3			
	INTERMITTENT LOADING	CONTINUOUS LOADING	CYCLICAL LOADING	INTERMITTENT LOADING	CONTINUOUS LOADING	CYCLICAL LOADING	INTERMITTENT LOADING	CONTINUOUS LOADING	CYCLICAL LOADING	
PSFT20CR	4400	2200	1200	1900	900	500	1300	700	400	18
PSFT3/4CR	4400	2200	1200	1900	900	500	1300	700	400	18
PSFT25CR	4400	2200	1200	3000	1500	800	1400	700	400	25
PSFT1CR	4400	2200	1200	3000	1500	800	1400	700	400	25
PSFT30CR	5900	2900	1600	3300	1600	900	2000	1000	500	30
PSFT1.3/16CR	5900	2900	1600	3300	1600	900	2000	1000	500	30
PSFT1.1/4RCR	5900	2900	1600	3300	1600	900	2000	1000	500	30
PSFT35CR	6400	3200	1700	3900	2000	1100	2800	1400	800	35
PSFT1.1/4CR	6400	3200	1700	3900	2000	1100	2800	1400	800	35
PSFT1.7/16CR	6400	3200	1700	3900	2000	1100	2800	1400	800	35
PSFT40CR	9000	4500	2500	3900	2000	1100	3300	1600	900	40
PSFT1.1/2CR	9000	4500	2500	3900	2000	1100	3300	1600	900	40

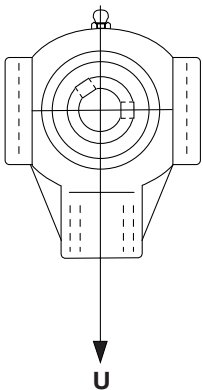

PST SECTION

Table 13 PST Silver-Lube® Take-Up – Housing Load Capacity

RHP DESIGNATION	MAXIMUM HOUSING LOAD (N) AT 20°C			
	U		Cyclical Loading	MRFL (kN)
Intermittent Loading	Continuous Loading	Intermittent Loading		
PST20CR	5700	2800	1600	17.01
PST3/4CR	5700	2800	1600	17.01
PST25CR	5400	2700	1500	16.25
PST1CR	5400	2700	1500	16.25
PST30CR	8100	4000	2300	24.32
PST1.3/16CR	8100	4000	2300	24.32
PST1.1/4RCR	8100	4000	2300	24.32
PST35CR	7800	3900	2200	23.52
PST1.1/4CR	7800	3900	2200	23.52
PST1.7/16CR	7800	3900	2200	23.52
PST40CR	8100	4000	2300	24.26
PST1.1/2CR	8100	4000	2300	24.26

Note that there is no Maximum Fixing Bolt Torque applicable for Take-Up Units.

STATIC ELECTRICITY GENERATION

Static electricity may be generated by Silver-Lube® bearing units under certain application conditions.

Silver-Lube® bearings are therefore not recommended for use in explosive or flammable environments. If Silver-Lube® bearing units are used in flammable or explosive applications the bearing insert must be earthed.



FROM FOOD TO PHARMACEUTICALS

SILVER-LUBE® BEARING INSERTS

The grease in this product is an aluminium complex food grade grease. In the event of relubricating being necessary, this type of grease is the first choice replacement. Please note that Silver-Lube® bearings were previously charged with Chevron Poly FM2 grease, which is incompatible with the current aluminium complex food grade grease.

Original Chevron greased inserts can be identified by there being only three markings on the flinger, for example: 'RHP JAPAN J1025-25GCR'. Inserts charged with an aluminium complex food grade grease can be identified by the presence of an additional letter between RHP and Japan; for example inserts are marked with a 'K' (or 'M') to give 'RHP K JAPAN J1025-25GCR'.

If an aluminium complex food grade grease is not available, it is essential that any alternative grease is USDA H1 approved and ideally chemically compatible with the original grease. If chemical compatibility cannot be assured, then it is recommended that the original grease is completely flushed out from the system before relubrication. NSK should be consulted if necessary.

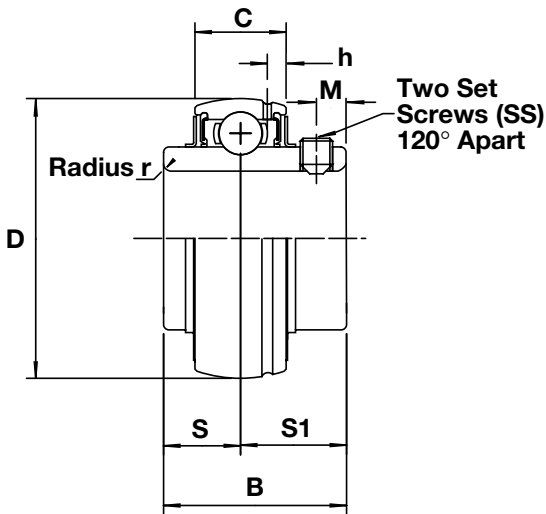

INSERT DESIGNATIONS, DIMENSIONS AND WEIGHTS

Table 14

Insert Dimensions

RHP DESIGNATION	BORE DIA	D	C	B	S	S1	r	h	M	SS	Cr (N)	Cor (N)	WEIGHT (kg)
J1020-20GCR	20	47	16	31.0	12.7	18.3	1.5	4.0	5.0	M6	9910	5350	0.16
J1020-3/4GCR	3/4"	47	16	31.0	12.7	18.3	1.5	4.0	5.0	M6	9910	5350	0.16
J1025-25GCR	25	52	17	34.0	14.3	19.7	1.5	3.5	5.5	M6	10820	6300	0.20
J1025-1GCR	1"	52	17	34.0	14.3	19.7	1.0	3.5	5.5	M6	10820	6300	0.20
J1030-30GCR	30	62	19	38.1	15.9	22.2	1.5	4.5	6.0	M6	15000	9050	0.32
J1030-1.3/16GCR	1.3/16"	62	19	38.1	15.9	22.2	1.0	4.5	6.0	M6	15000	9050	0.32
J1030-1.1/4GCR	1.1/4"	62	19	38.1	15.9	22.2	1.0	4.5	6.0	M6	15000	9050	0.32
J1035-35GCR	35	72	20	42.9	17.5	25.4	2.0	4.5	6.5	M8	19820	12300	0.48
J1035-1.1/4GCR	1.1/4"	72	20	42.9	17.5	25.4	2.0	4.5	6.5	M8	19820	12300	0.48
J1035-1.7/16GCR	1.7/16"	72	20	42.9	17.5	25.4	1.5	4.5	6.5	M8	19820	12300	0.48
J1040-40GCR	40	80	21	49.2	19.0	30.2	2.0	4.5	8.0	M8	22540	14300	0.64
J1040-1.1/2GCR	1.1/2"	80	21	49.2	19.0	30.2	2.0	4.5	8.0	M8	22540	14300	0.64

All dimensions in mm except inch bores. Cr = basic dynamic load rating. Cor = basic static load rating. Contact NSK for guidance on life estimation.

COMPONENT MATERIALS

Table 15

STANDARD	BEARING RINGS	BALL	FLINGER	SET SCREW	CAGE
JIS	SUS440C	SUS440C	SUS304	SUS410	SUS304
AISI/ASTM	AISI440C	AISI440C	AISI304	AISI410	AISI304

SHAFT TOLERANCES AND PERMISSIBLE SPEEDS

Bearing insert permissible speed is dependent on shaft tolerance.

For higher speed applications an ISO h7 shaft tolerance is recommended. An ISO h9 shaft tolerance may be used for low speed applications. For more details see table 16.

Table 16

Tolerances and Speeds

BASIC BEARING INSERT	BEARING LIMITING SPEED (RPM)	ISO h7		BEARING LIMITING SPEED (RPM)	ISO h9	
		SHAFT TOLERANCE HIGH (0.001 mm UNITS)	SHAFT TOLERANCE LOW (0.001 mm UNITS)		SHAFT TOLERANCE HIGH (0.001 mm UNITS)	SHAFT TOLERANCE LOW (0.001 mm UNITS)
J1020	2900	0	-21	1490	0	-52
J1025	2600	0	-21	1300	0	-52
J1030	2180	0	-21	1090	0	-52
J1035	1870	0	-25	940	0	-62
J1040	1650	0	-25	830	0	-62



SET SCREW TIGHTENING TORQUES

Set screws for Silver-Lube® bearing inserts are manufactured from stainless steel and can fracture if overtightened. The limiting set screw torques listed below should not be exceeded.

Table 17

Tightening Torques

RHP DESIGNATION	SET SCREW	MAXIMUM TIGHTENING TORQUE (Nm)
J1020-20GCR	M6 x 7.0 LONG	4
J1020-3/4GCR	M6 x 7.0 LONG	4
J1025-25GCR	M6 x 7.0 LONG	4
J1025-1GCR	M6 x 7.0 LONG	4
J1030-30GCR	M6 x 7.0 LONG	4
J1030-1.3/16GCR	M6 x 7.0 LONG	4
J1030-1.1/4GCR	M6 x 7.0 LONG	4
J1035-35GCR	M8 x 9.0 LONG	8
J1035-1.1/4GCR	M8 x 9.0 LONG	8
J1035-1.7/16GCR	M8 x 9.0 LONG	8
J1040-40GCR	M8 x 9.0 LONG	8
J1040-1.1/2GCR	M8 x 9.0 LONG	8

BORE TOLERANCE

Silver-Lube® inner ring bore tolerances are on the plus side of the nominal bore. This enables the bearing to slip freely over standard shafting.

Table 18

Bore Tolerances

NOMINAL BORE DIAMETER d (mm)		BORE TOLERANCE (0.001 mm UNITS)	
OVER	INCLUDING	MAX	MIN
10	18	+15	0
18	30	+18	0
30	50	+21	0

In line with our policy of continuous improvement, we reserve the right to amend the details in this catalogue without prior notice.

Townsend Bearings & Transmissions Limited

**Unit 1, St.Andrews Industrial Estate,
Bridport, Dorset. DT6 3EX. England.**

**Tel : 01308 456933 (UK only) +44 1308 456933 (Outside the UK)
Fax : 01308 427913 (UK only) +44 1308 427913 (Outside the UK)**

Email : sales@townsendbearings.co.uk

www.townsendbearings.co.uk